

UNITE USE CASES

28.05, 2018 HEILBRONN

beyerdynamic))))

UNITE TOUR GUIDE

beyerdynamic))))



UNITE

GUIDED TOUR CLASSIC

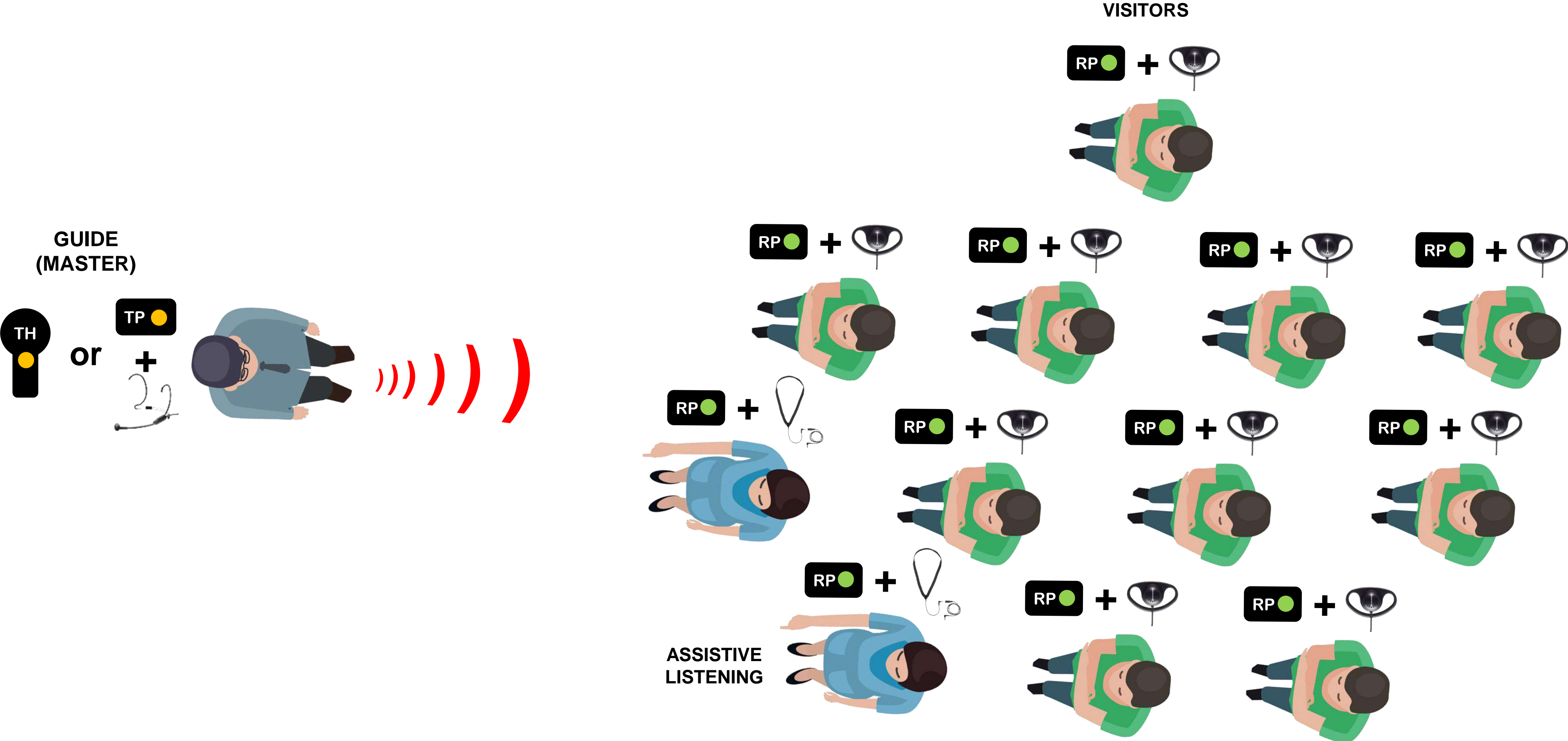

UNITE

GUIDED TOUR WITH TALKBACK

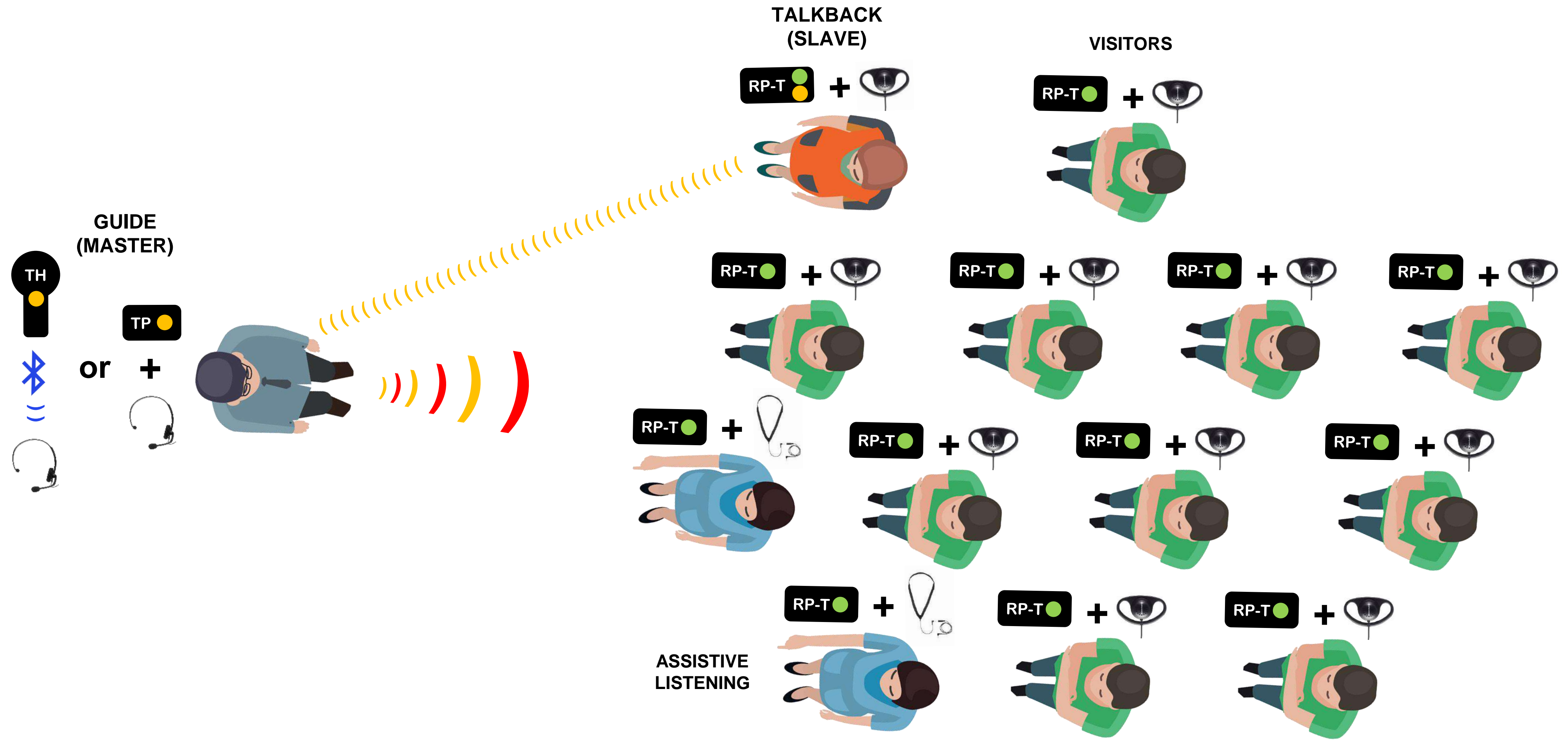

UNITE

GUIDED TOUR WITH AUDIO INPUT

EXAMPLES FOR AUDIO SOURCES

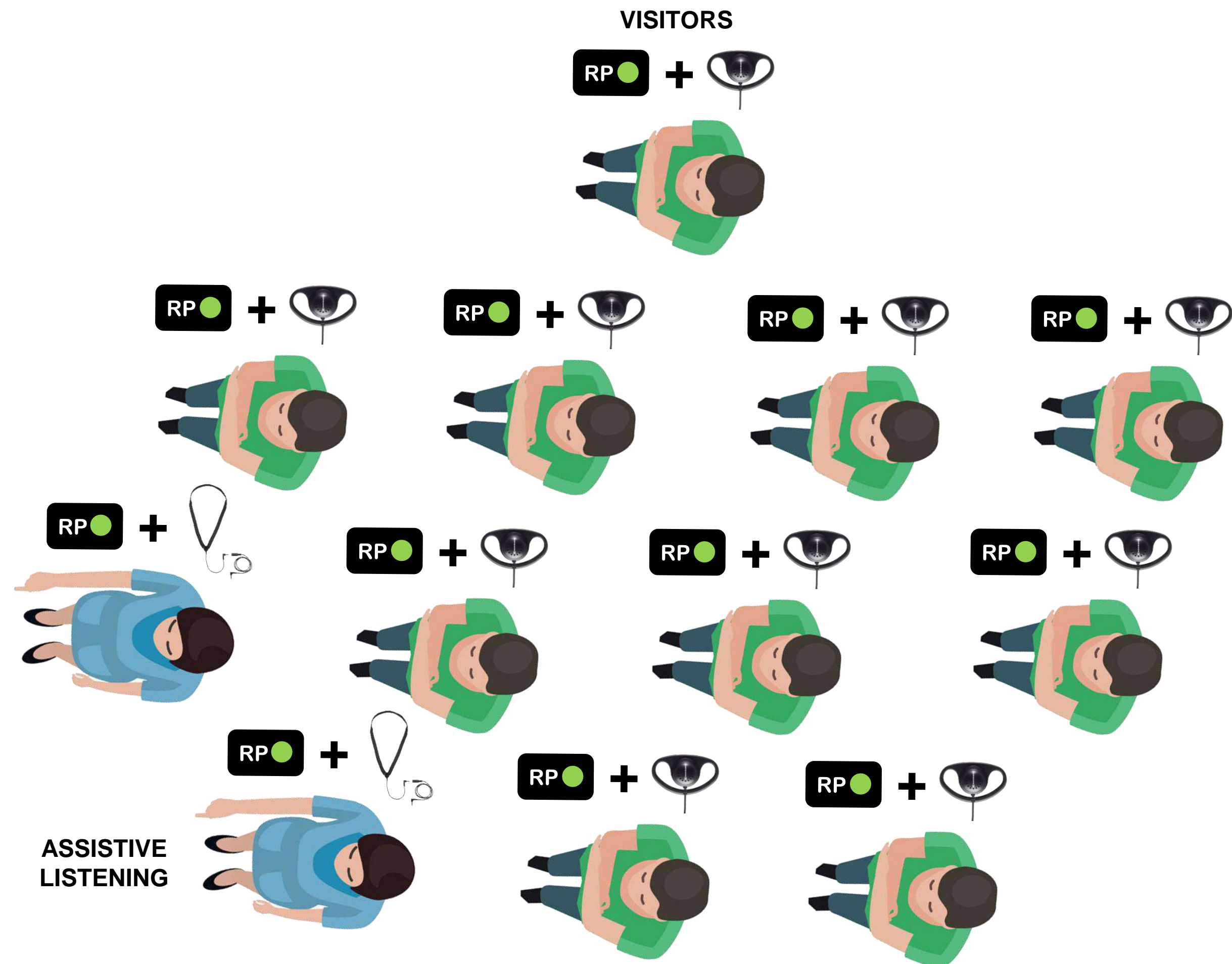
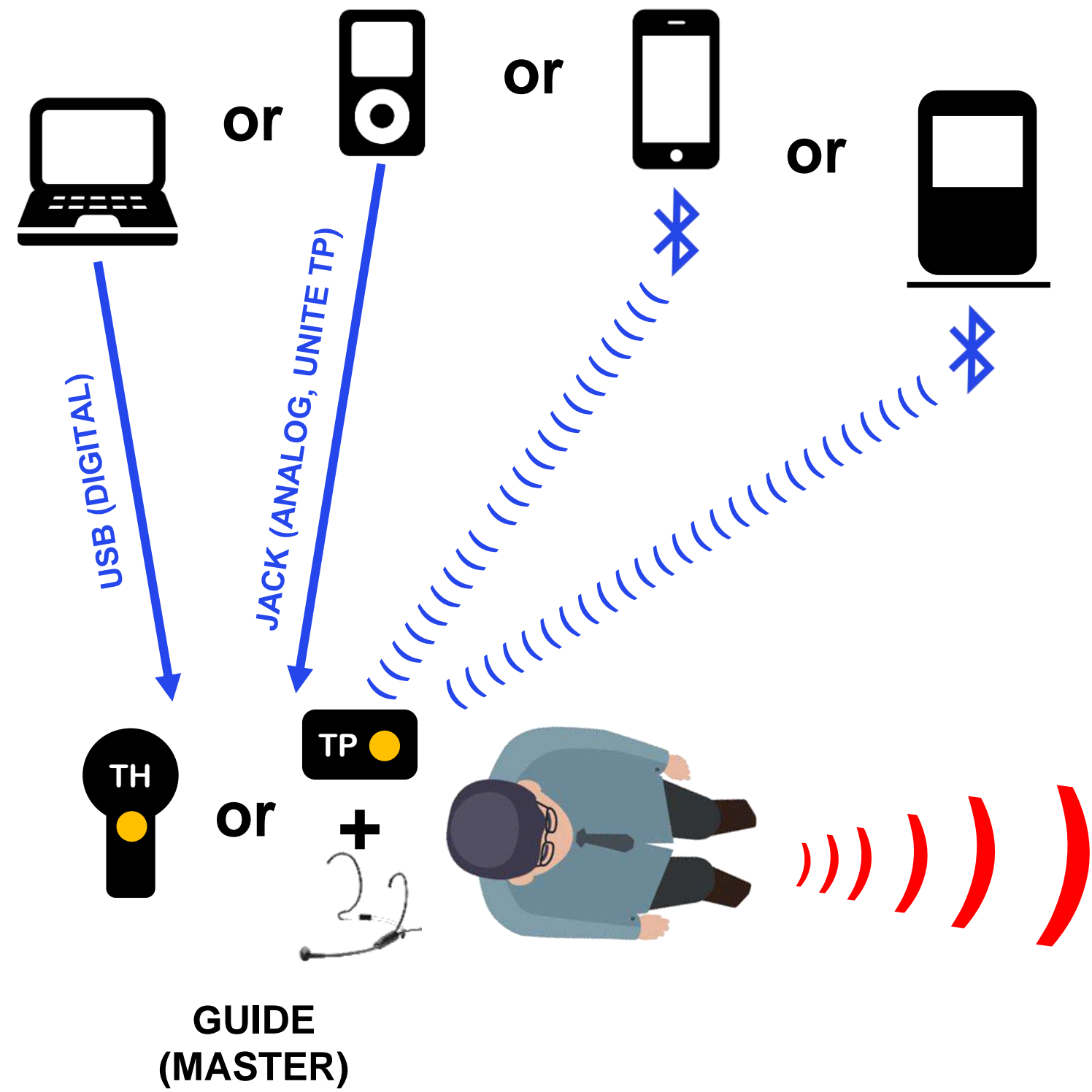

UNITE

GUIDED TOUR WITH TWO GUIDES

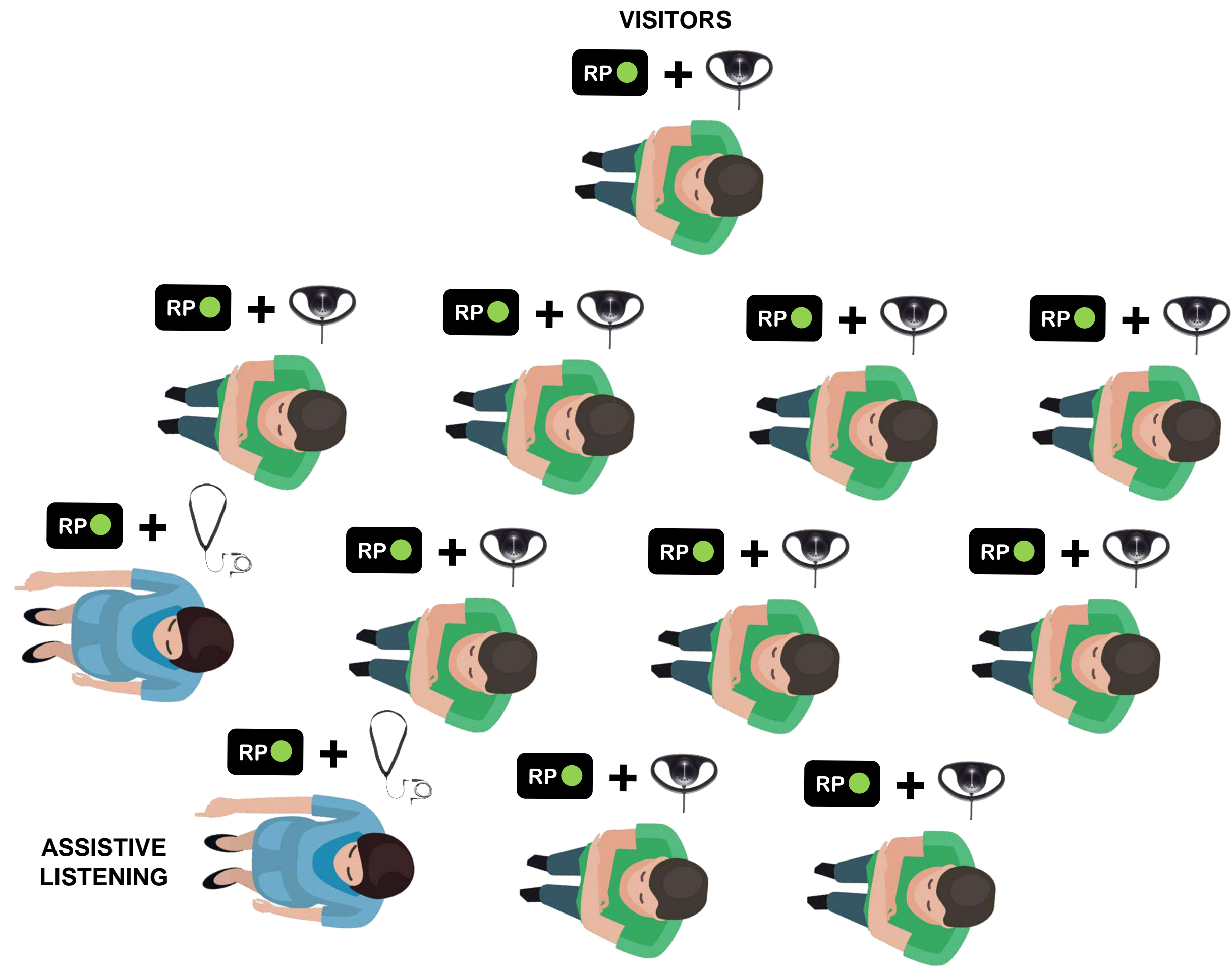
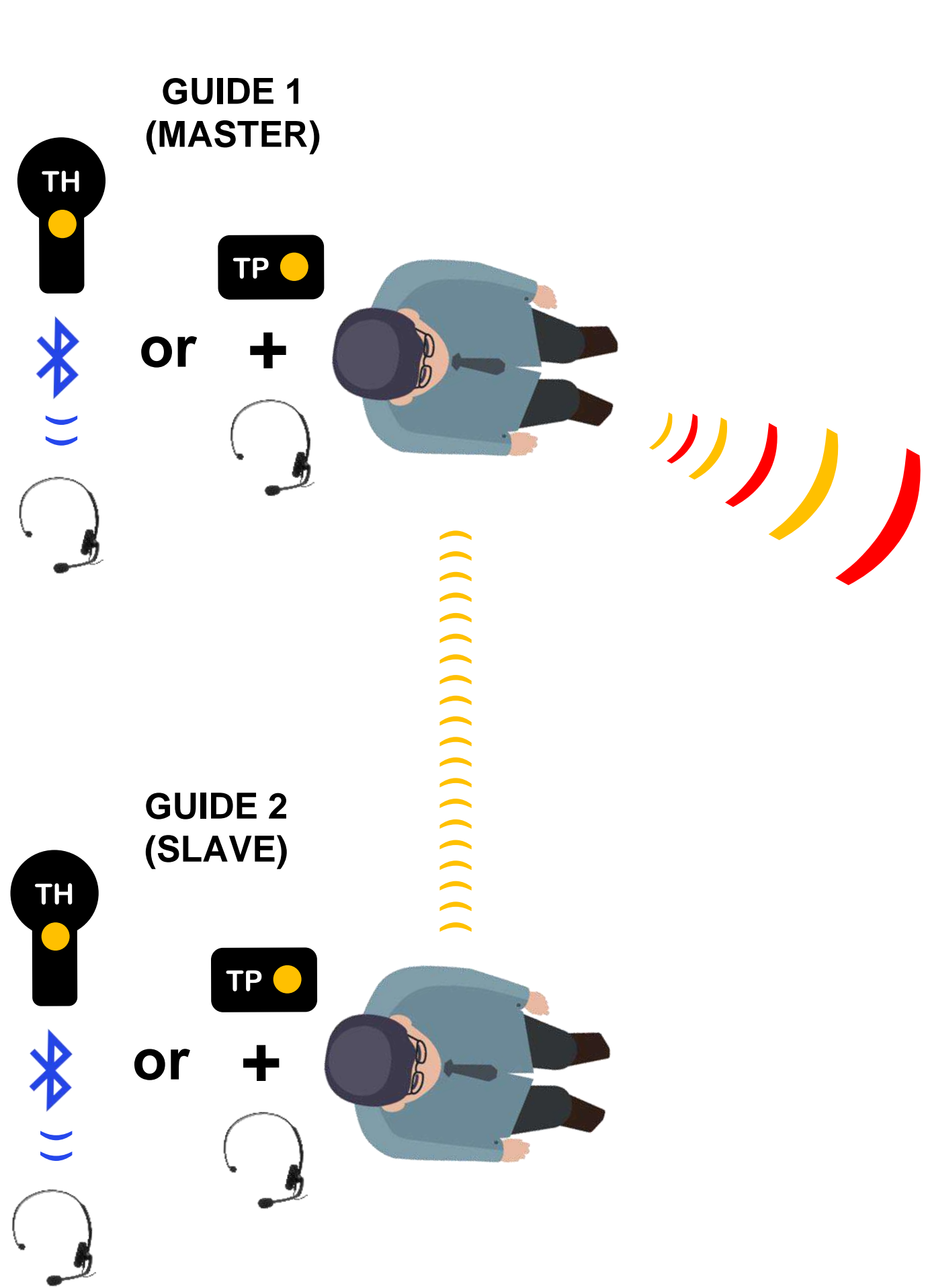

UNITE

GUIDED TOUR WITH WHISPERED INTERPRETATION

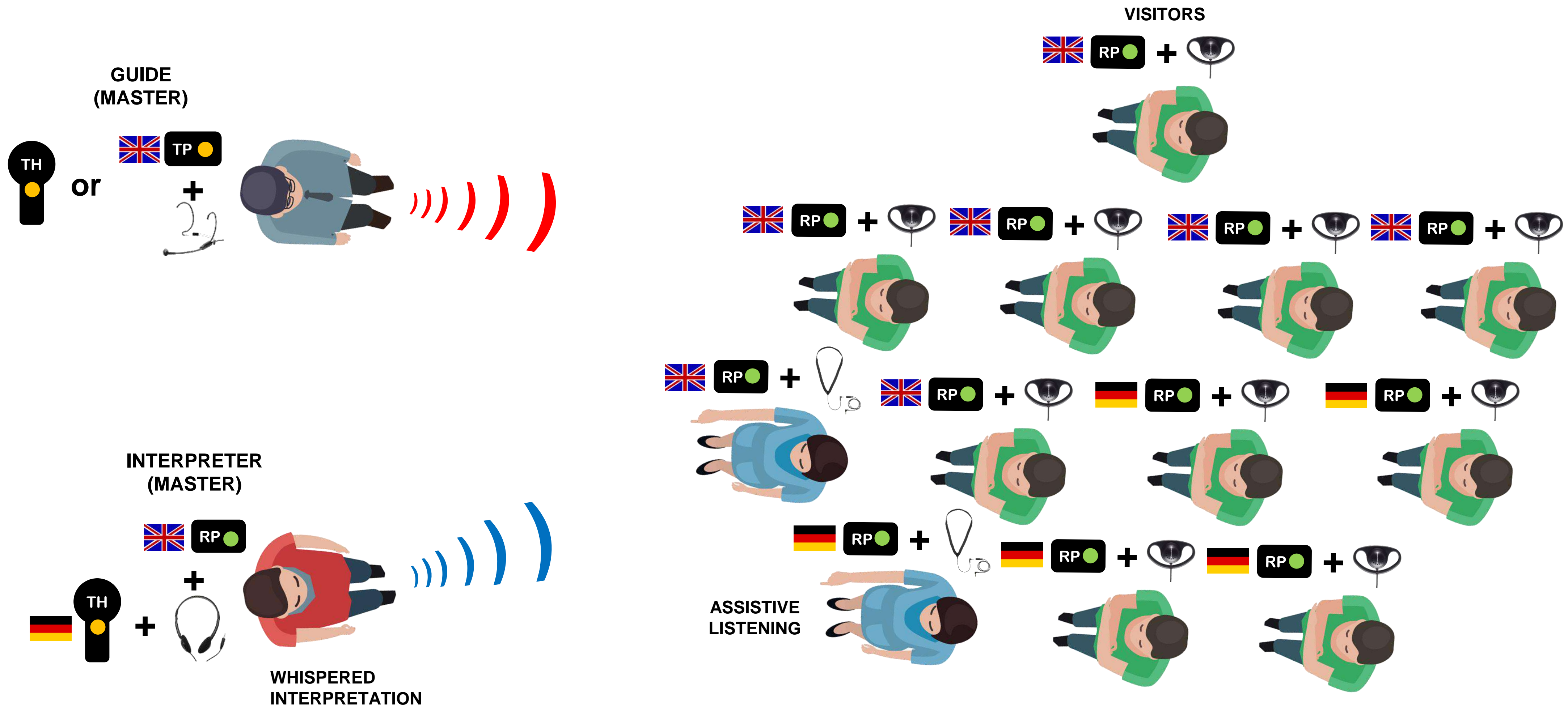

UNITE

GUIDED TOUR WITH SEVERAL GROUPS

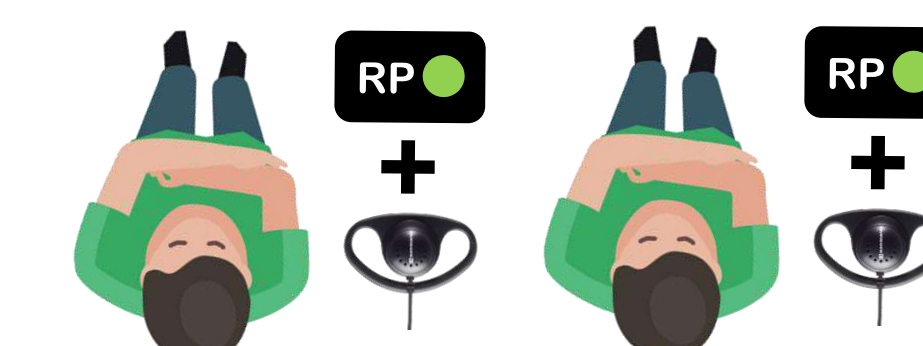
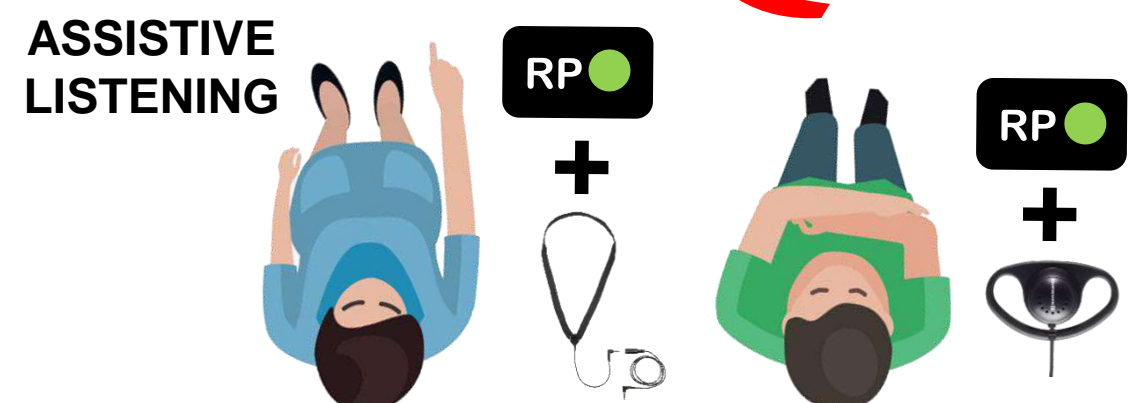
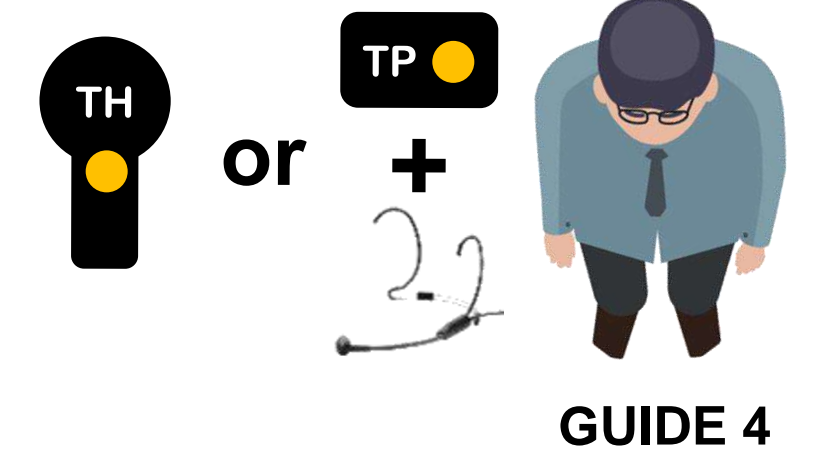
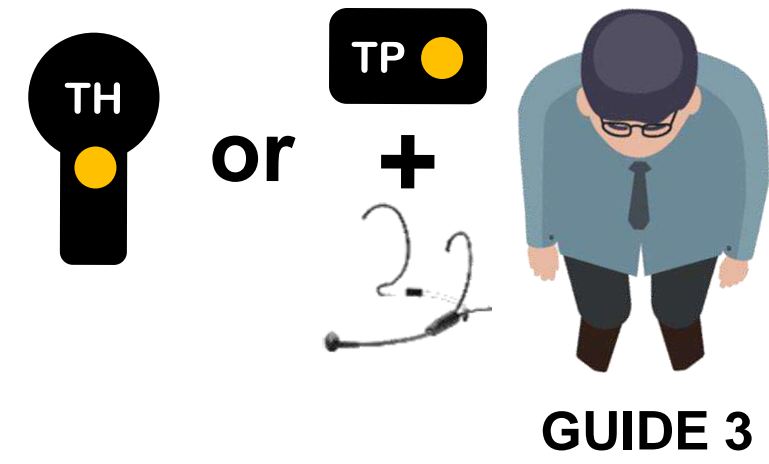
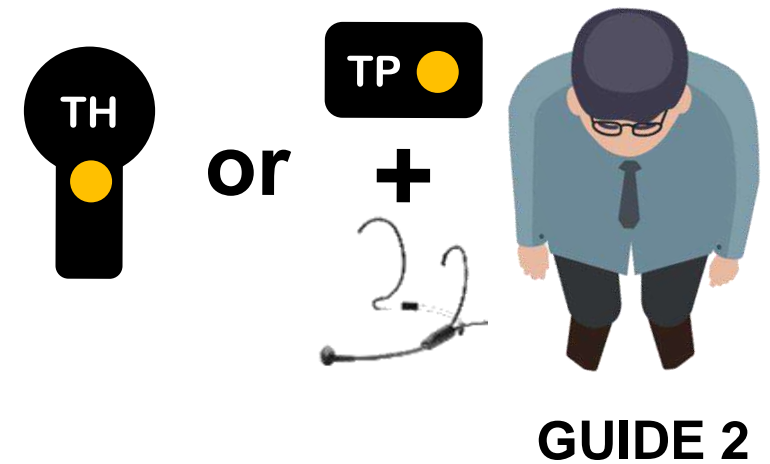
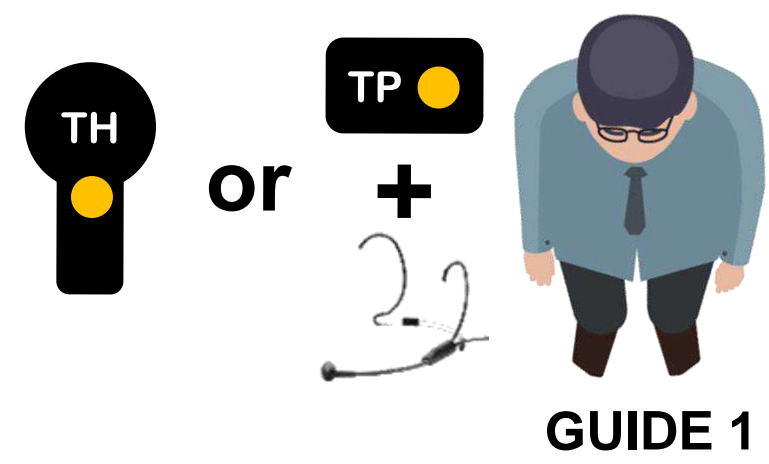

UNITE EVENT

beyerdynamic))))

UNITE

MOBILE EVENT WITH WIRELESS MICROPHONE, ACTIVE LOUDSPEAKER AND ASSISTIVE LISTENING

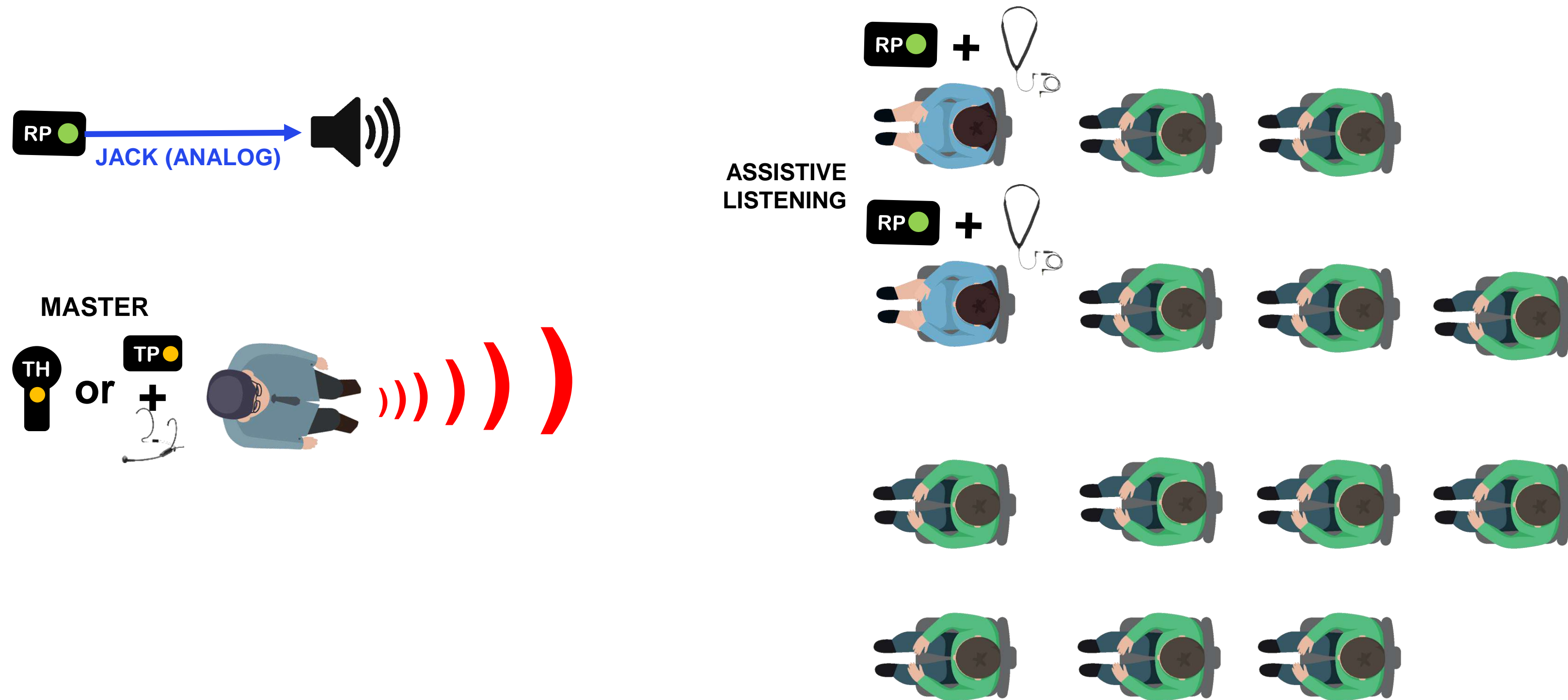

UNITE

EVENT WITH ASSISTIVE LISTENING,
SEVERAL SPEAKERS AND WITHOUT PA

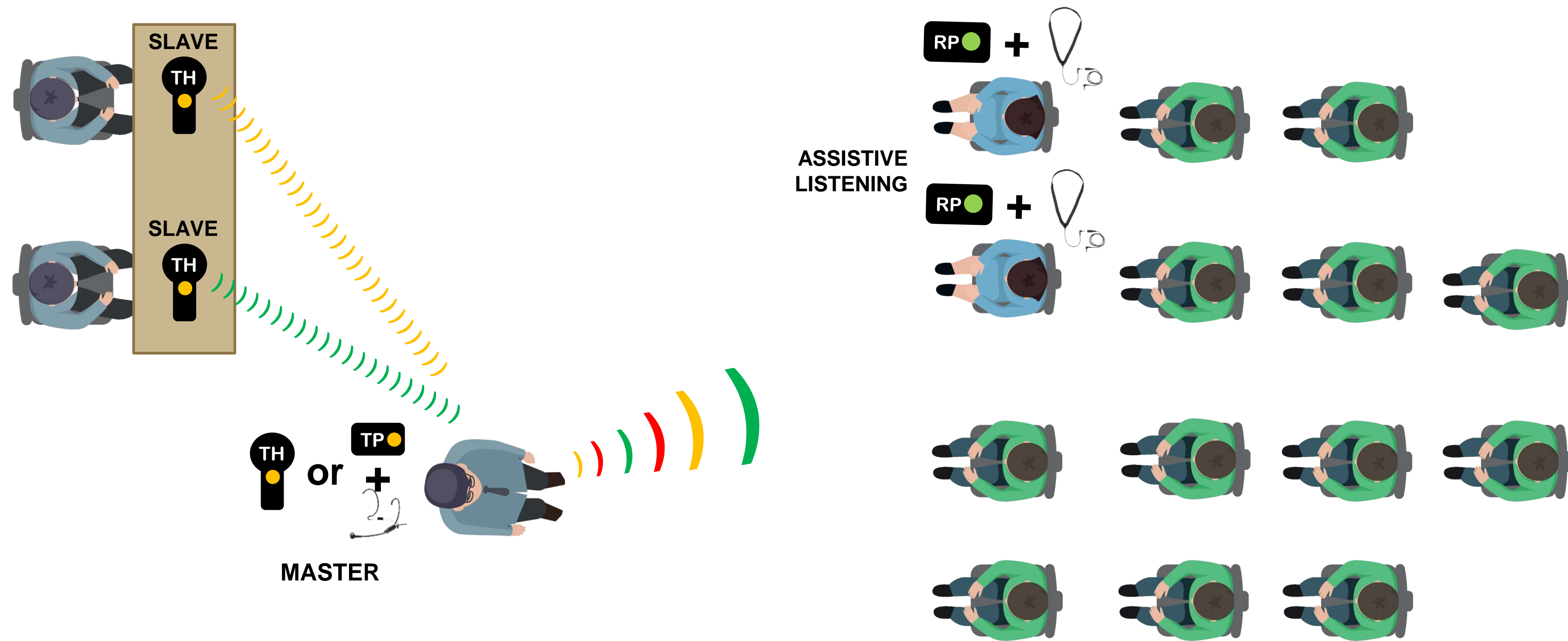

UNITE

EVENT WITH WIRELESS MICROPHONE, ASSISTIVE LISTENING AND PA

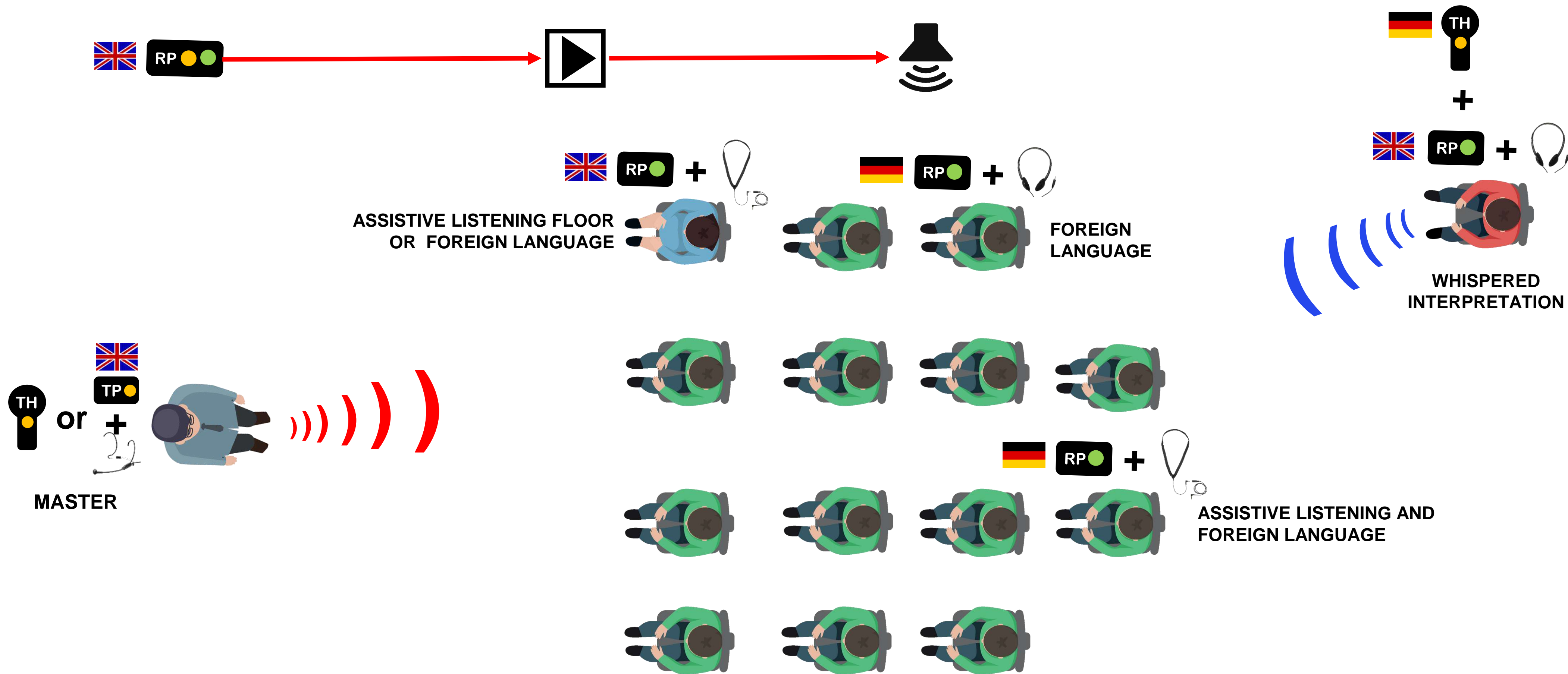

UNITE

EVENT WITH WIRELESS MICROPHONE,
WHISPERED INTERPRETATION AND ASSISTIVE LISTENING

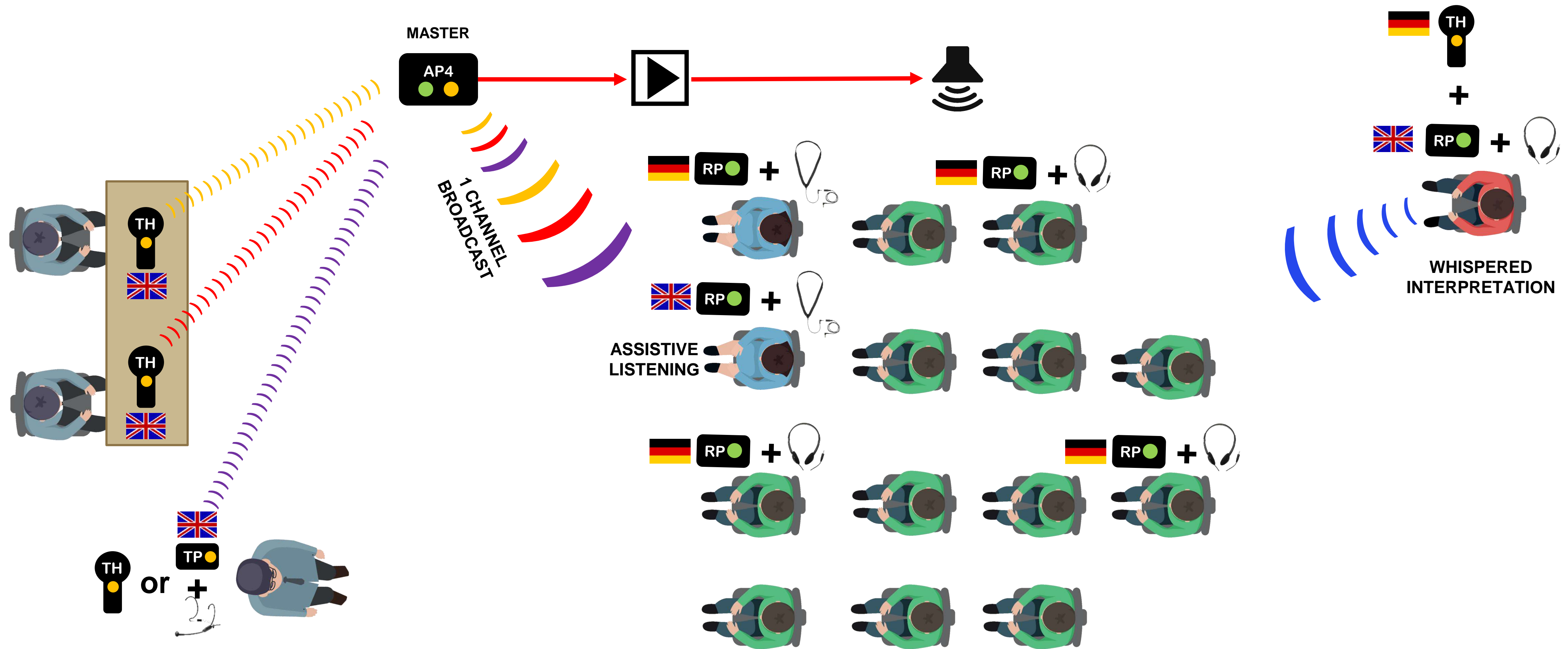

UNITE

EVENT WITH WIRELESS MICROPHONE, INTERPRETATION AND ASSISTIVE LISTENING

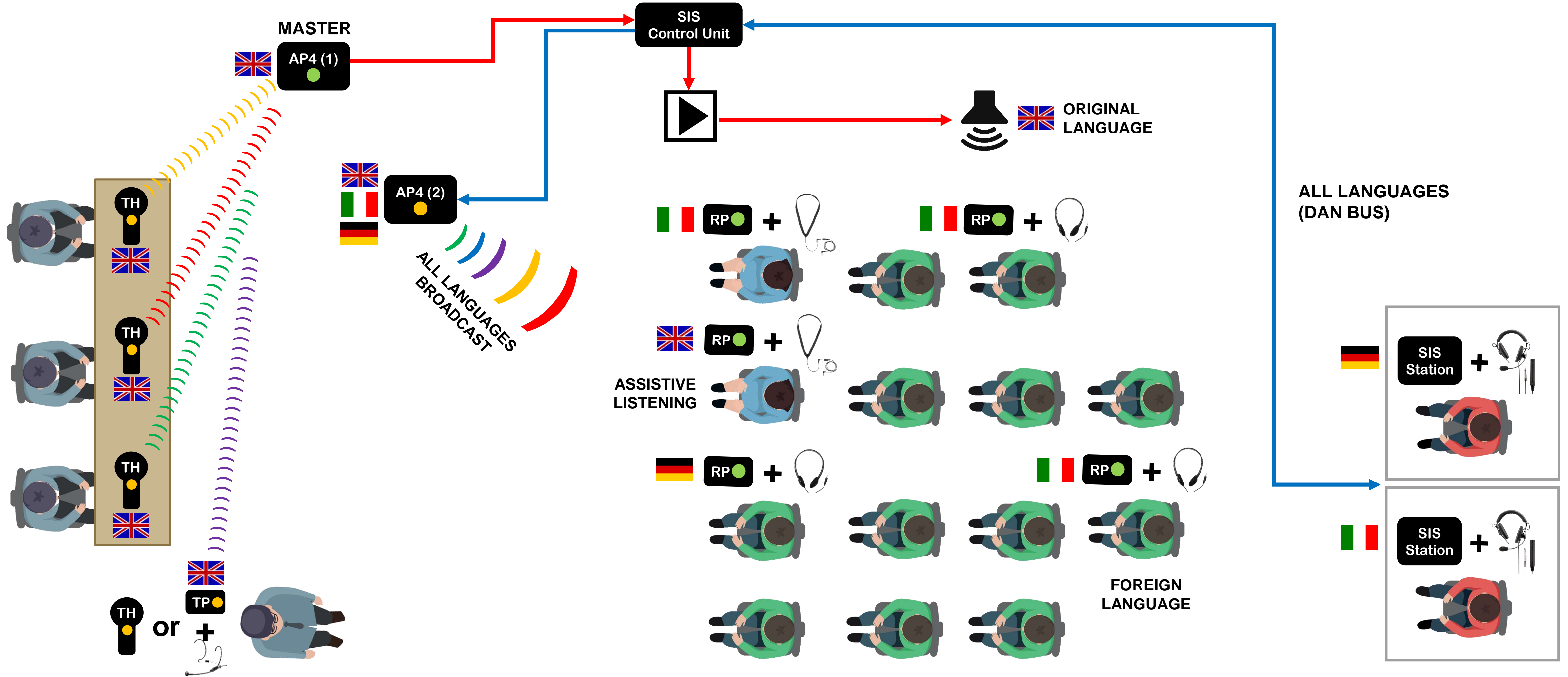

UNITE

DIGITAL MULTICHANNEL TRANSMISSION SILENT PA WITH ANTENNA

AUDIO IN – ANALOGUE OR DIGITAL (DANTE)

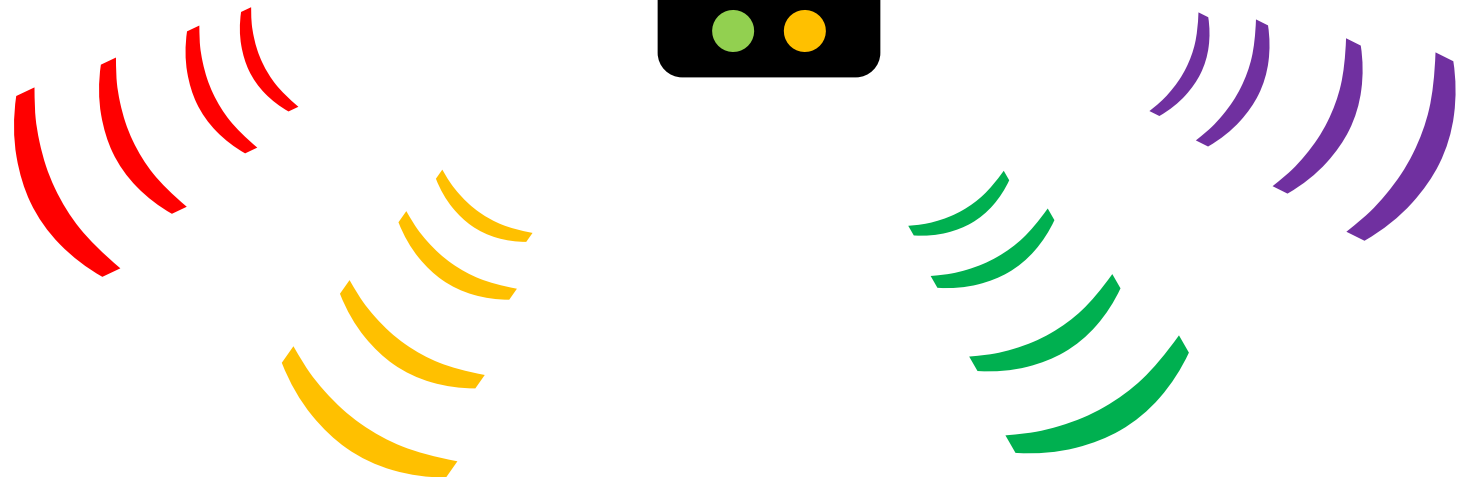
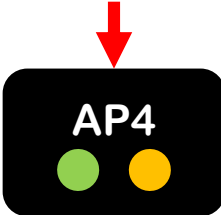

ASSISTIVE LISTENING

CONTENT 1

CONTENT 2

CONTENT 3

CONTENT 4

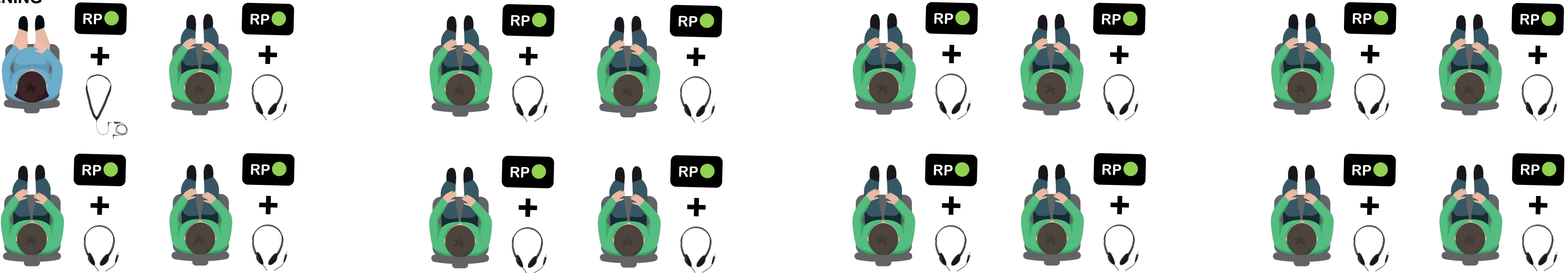

UNITE

DIGITAL MULTICHANNEL TRANSMISSION SILENT PA WITHOUT ANTENNA

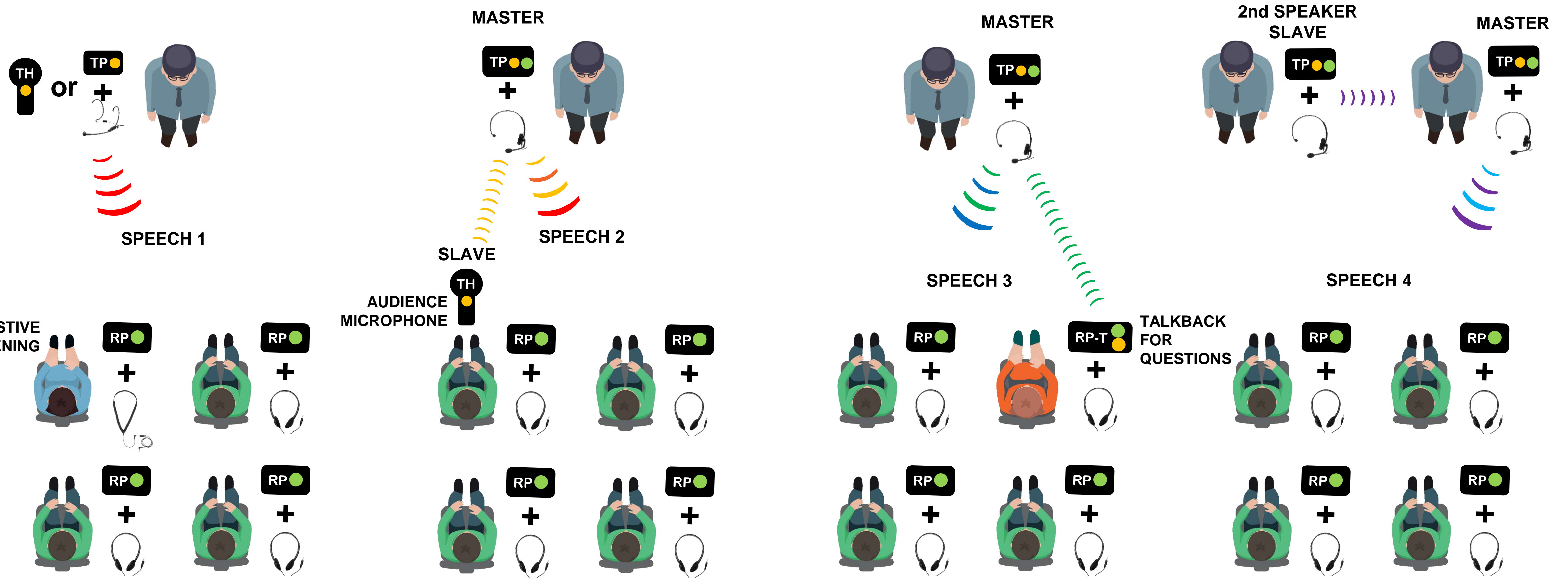

UNITE

CAMPUS APPLICATION WIRELESS MICROPHONE WITH REMOTE MONITORING

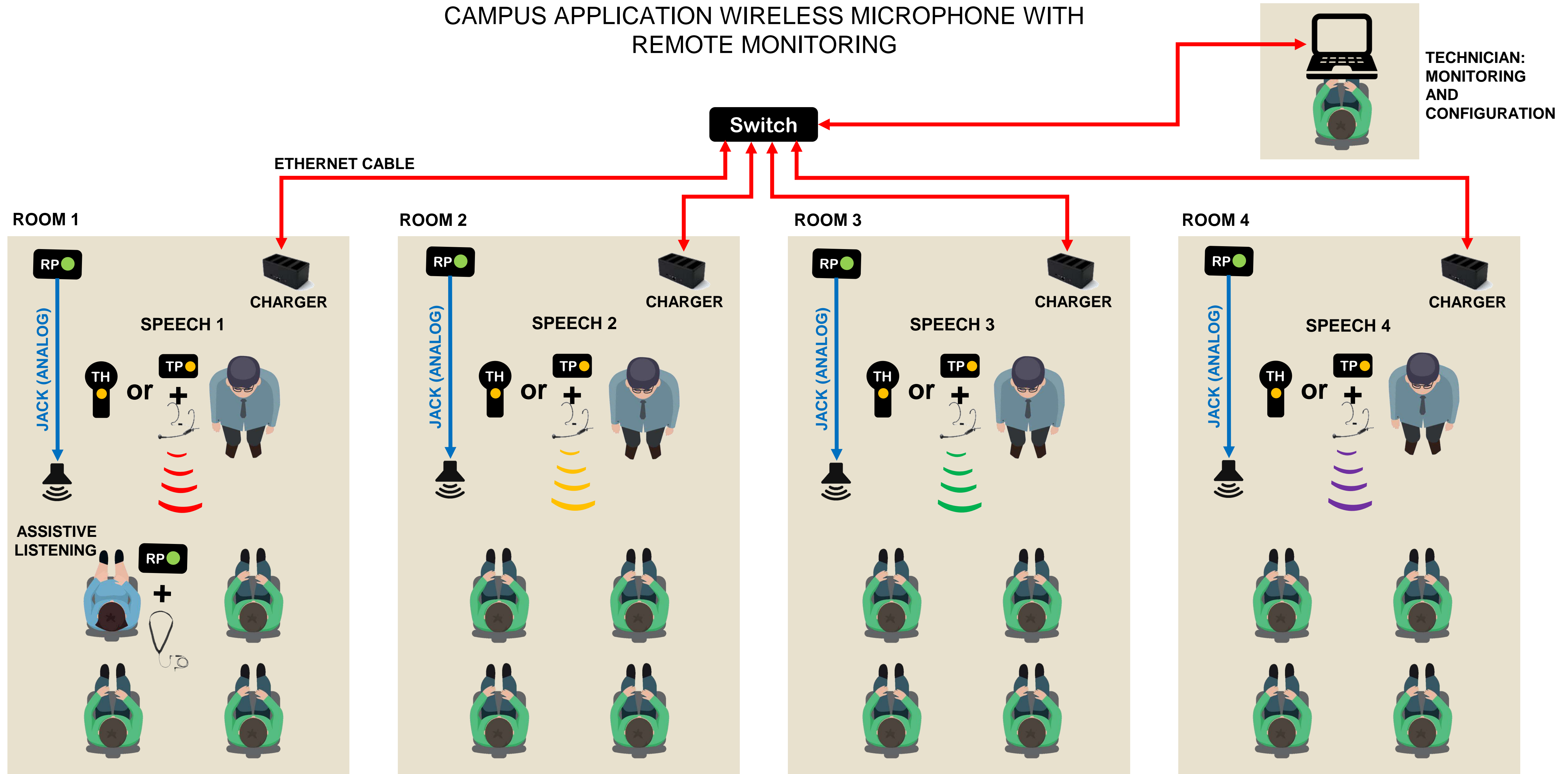

UNITE ASSISTIVE LISTENING

beyerdynamic))))

UNITE SCHOOL FOR HARD OF HEARING

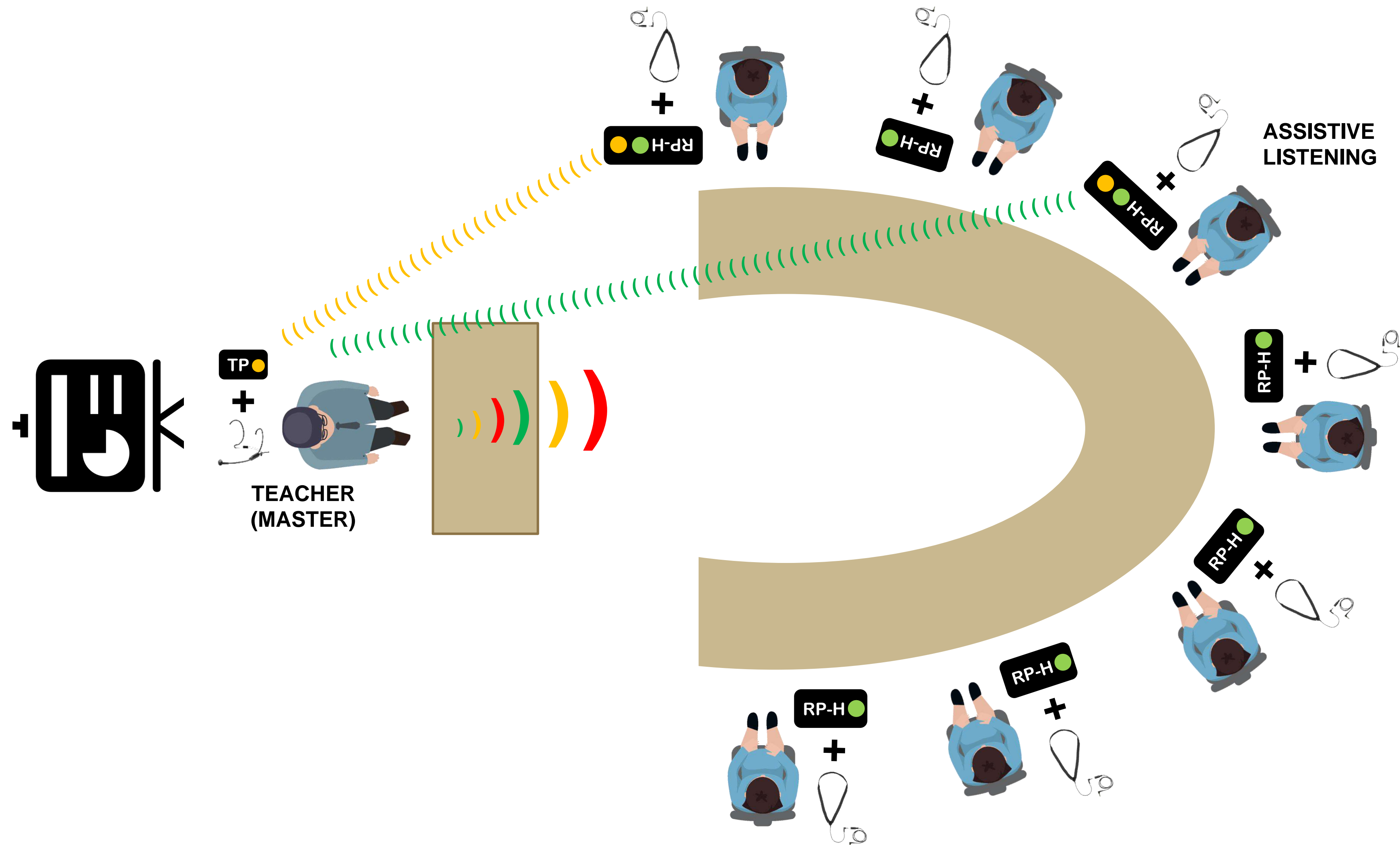

UNITE

INCLUSIVE CLASSES (HARD OF HEARING)

EXAMPLES FOR EXTERNAL AUDIO SOURCES

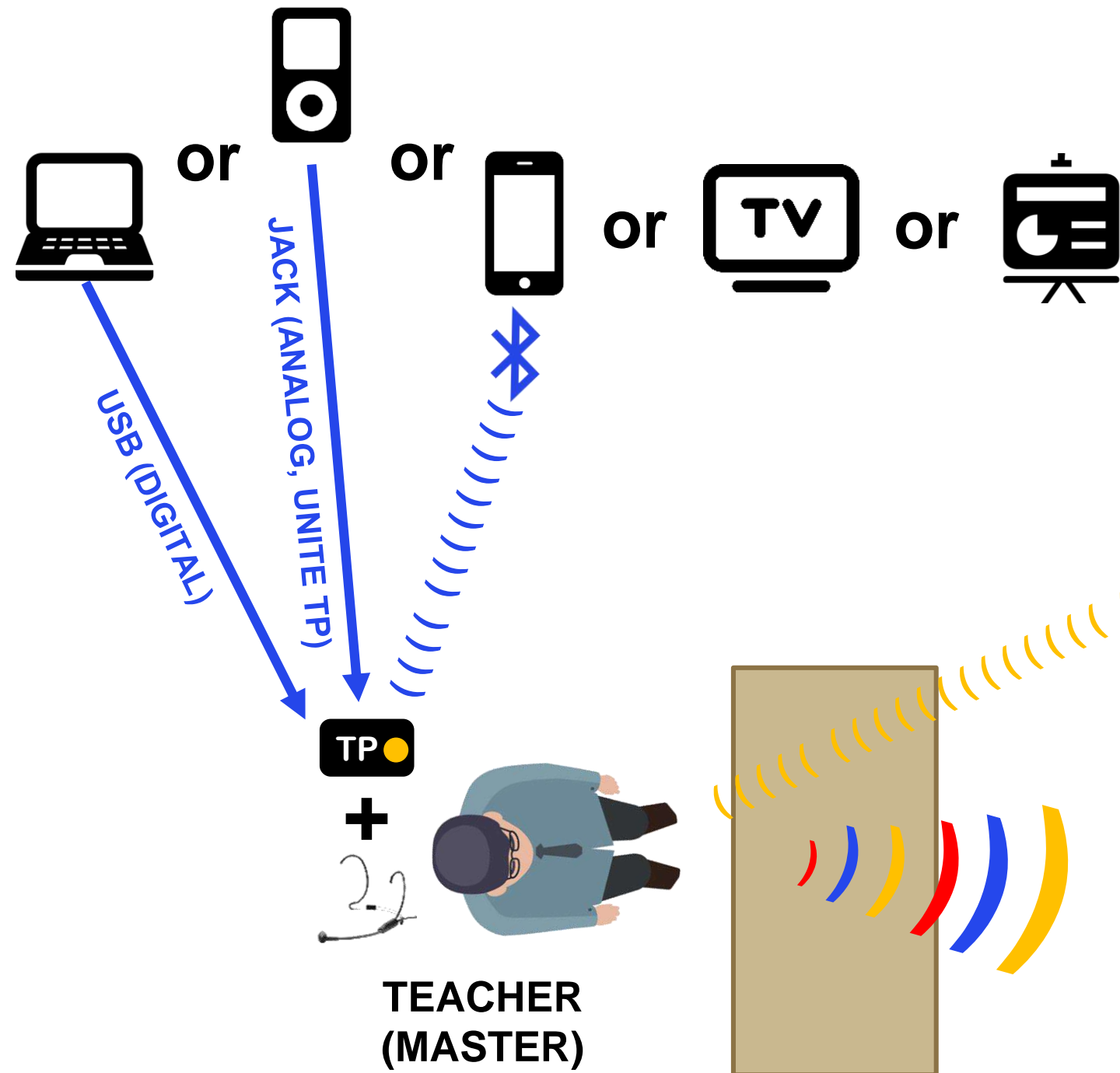

OPTIONAL:



CLASS MEMBERS



UNITE

DISCUSSION GROUP / WORKSHOP

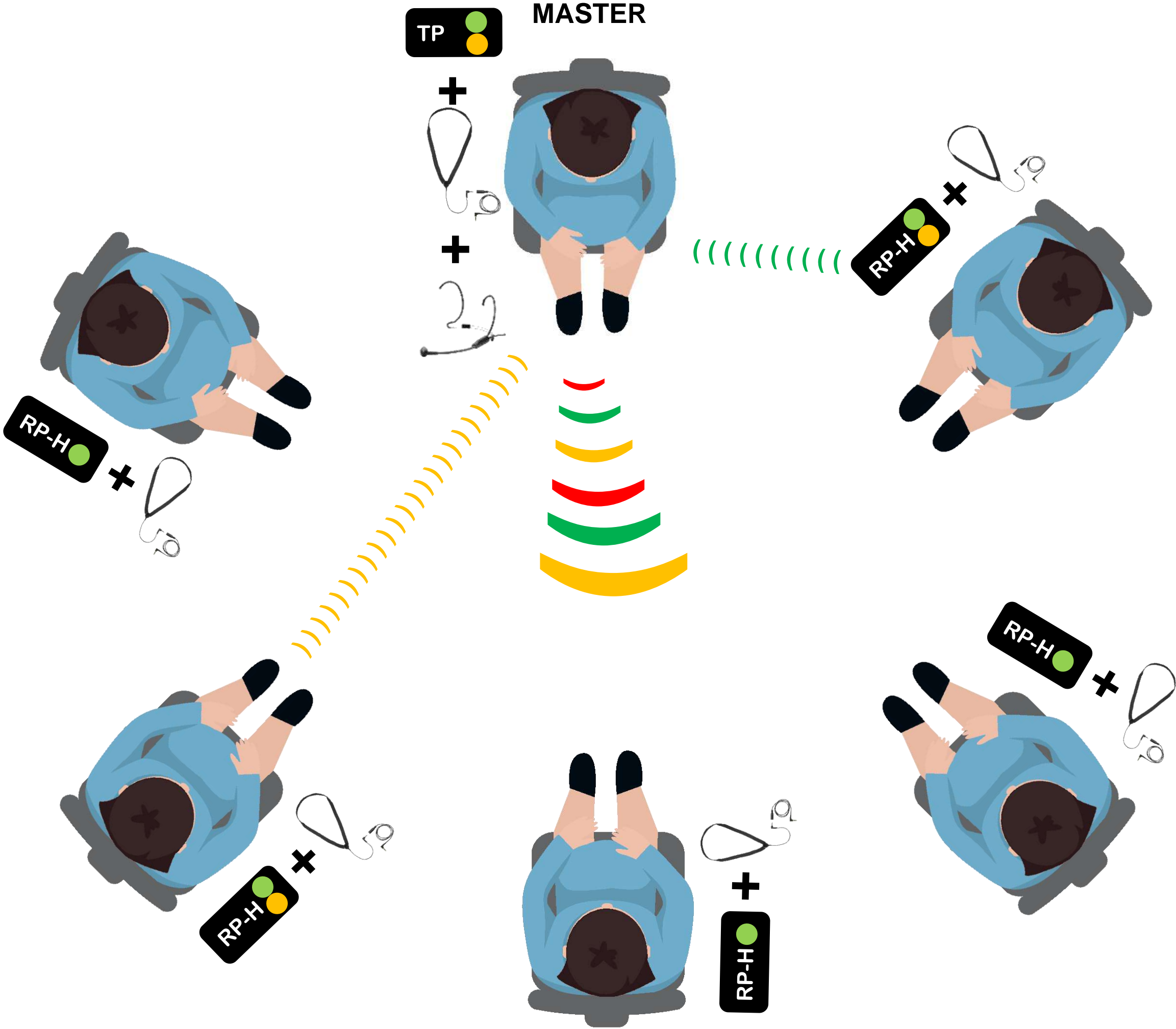

UNITE

ASSISTIVE LISTENING MOBILE FOR CONVERSATIONS

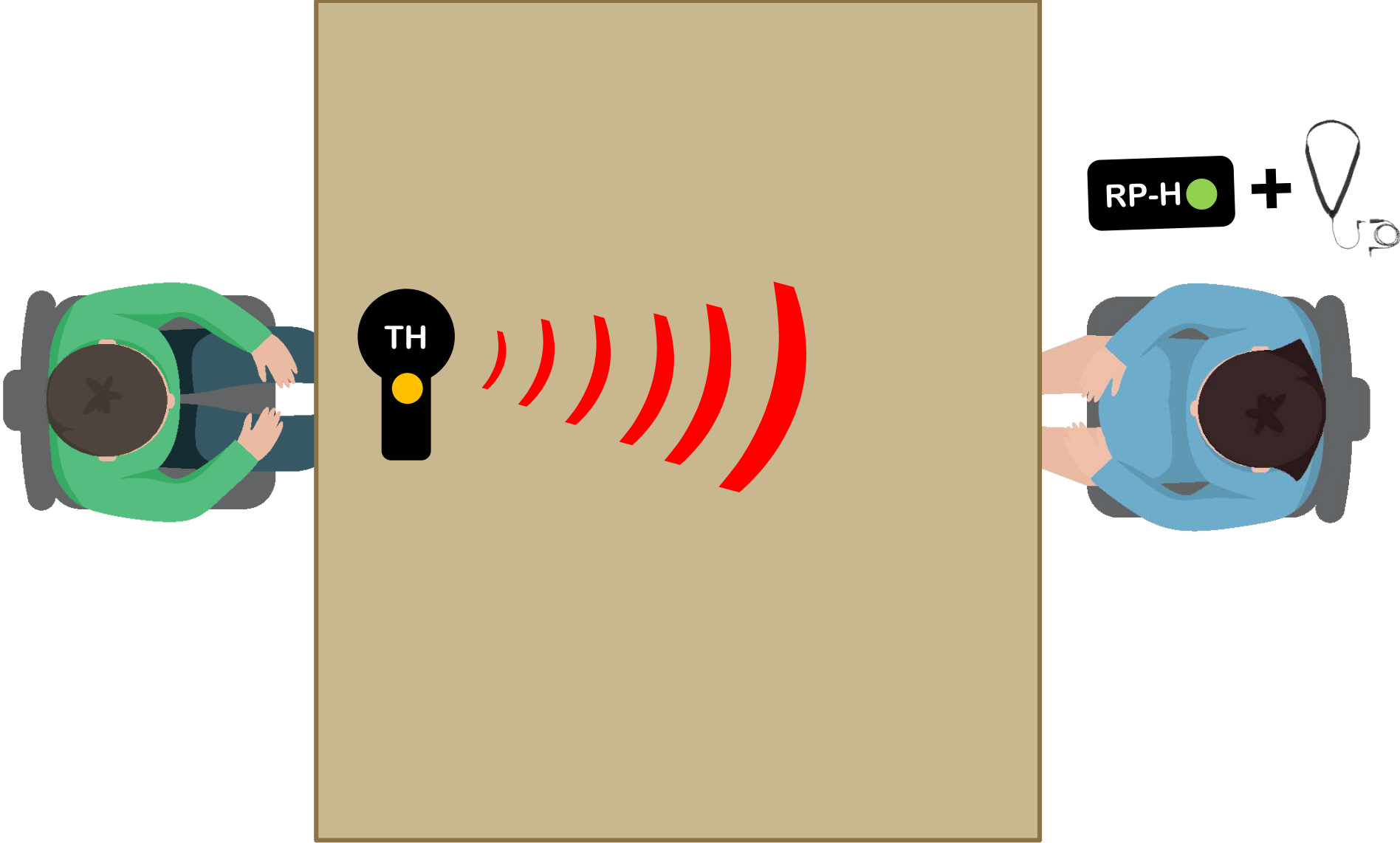

UNITE BLIND COVERAGE

beyerdynamic))))

UNITE

BLIND COVERAGE, ASSISTIVE LISTENING, FOREIGN LANGUAGE IN CINEMA

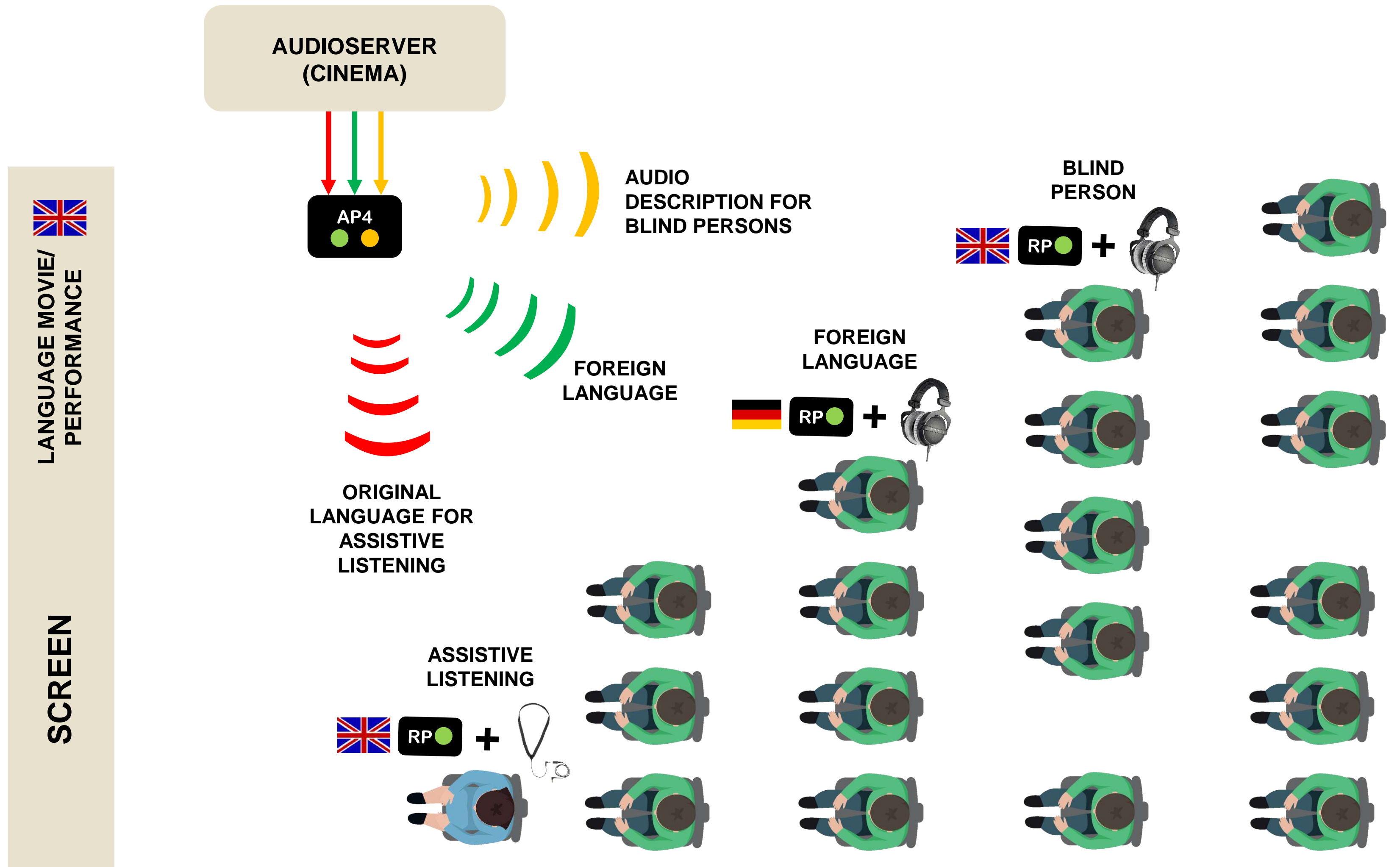

UNITE

BLIND COVERAGE WITH TWO REPORTERS AND MONITORING
(IN AUDIENCE)

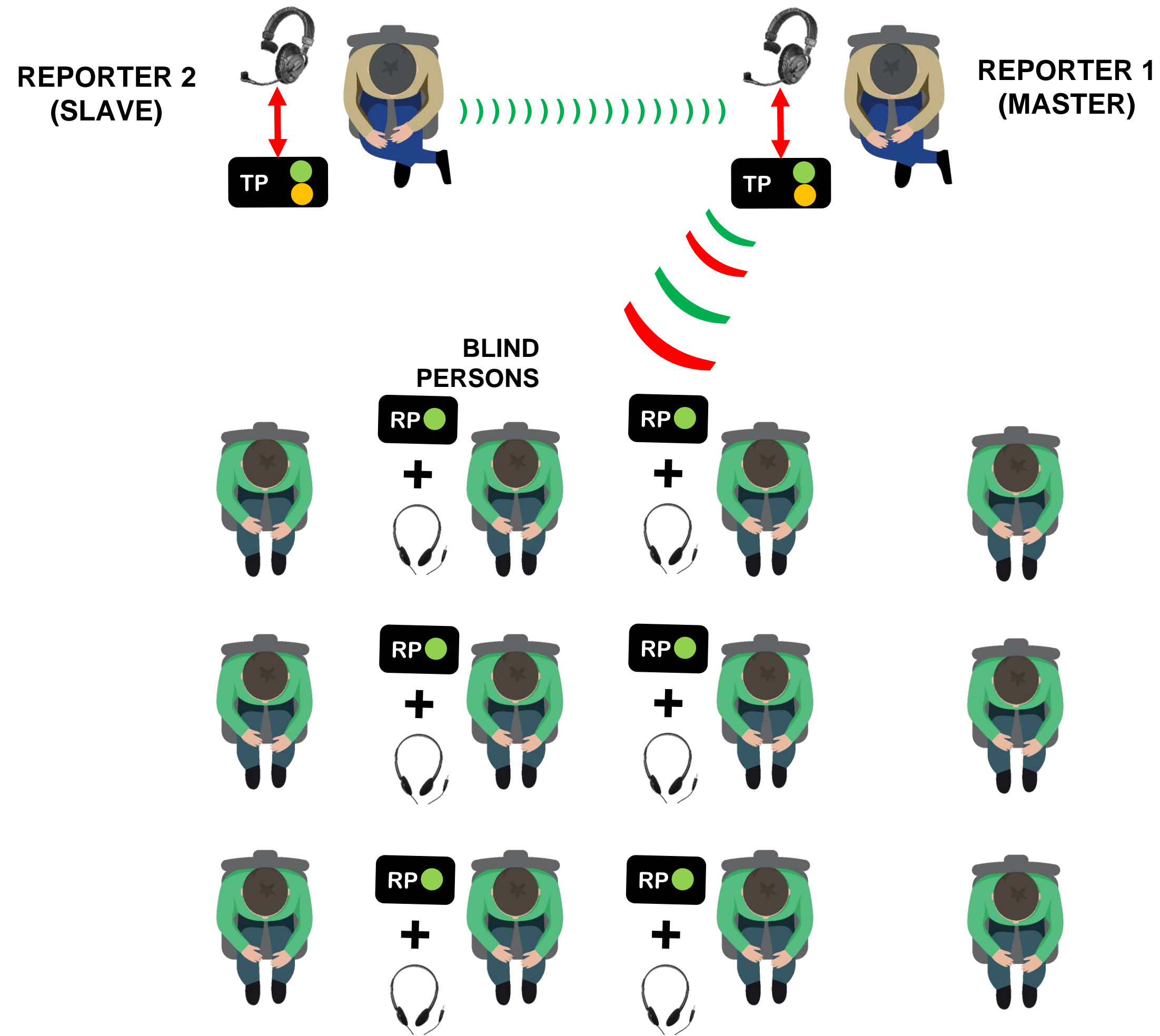

UNITE WIRELESS INTERCOM

beyerdynamic))))

UNITE

TRAINING / DIRECTION WITH TWO PARTICIPANTS
INTERCOM APPLICATION

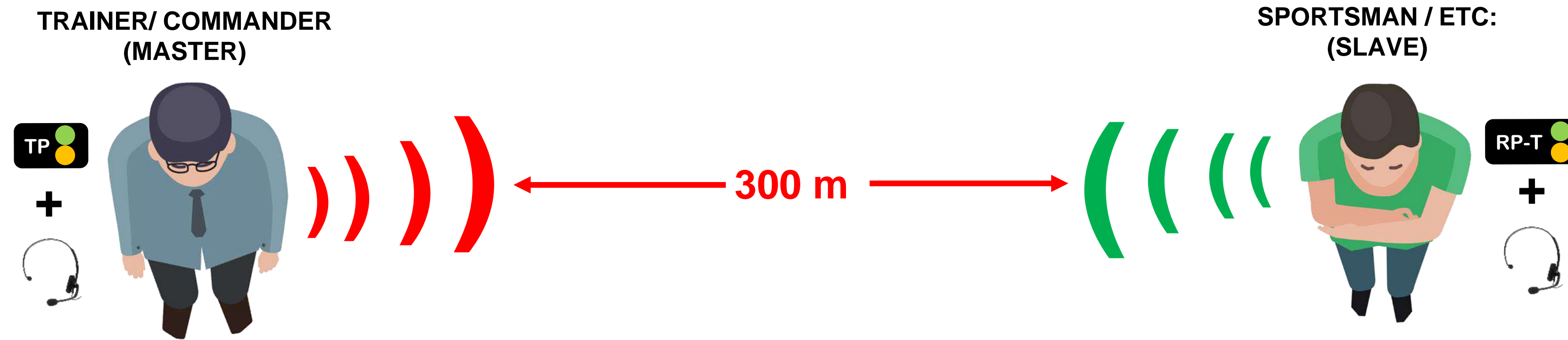

UNITE

TRAINING / DIRECTION WITH SEVERAL PARTICIPANTS
INTERCOM APPLICATION

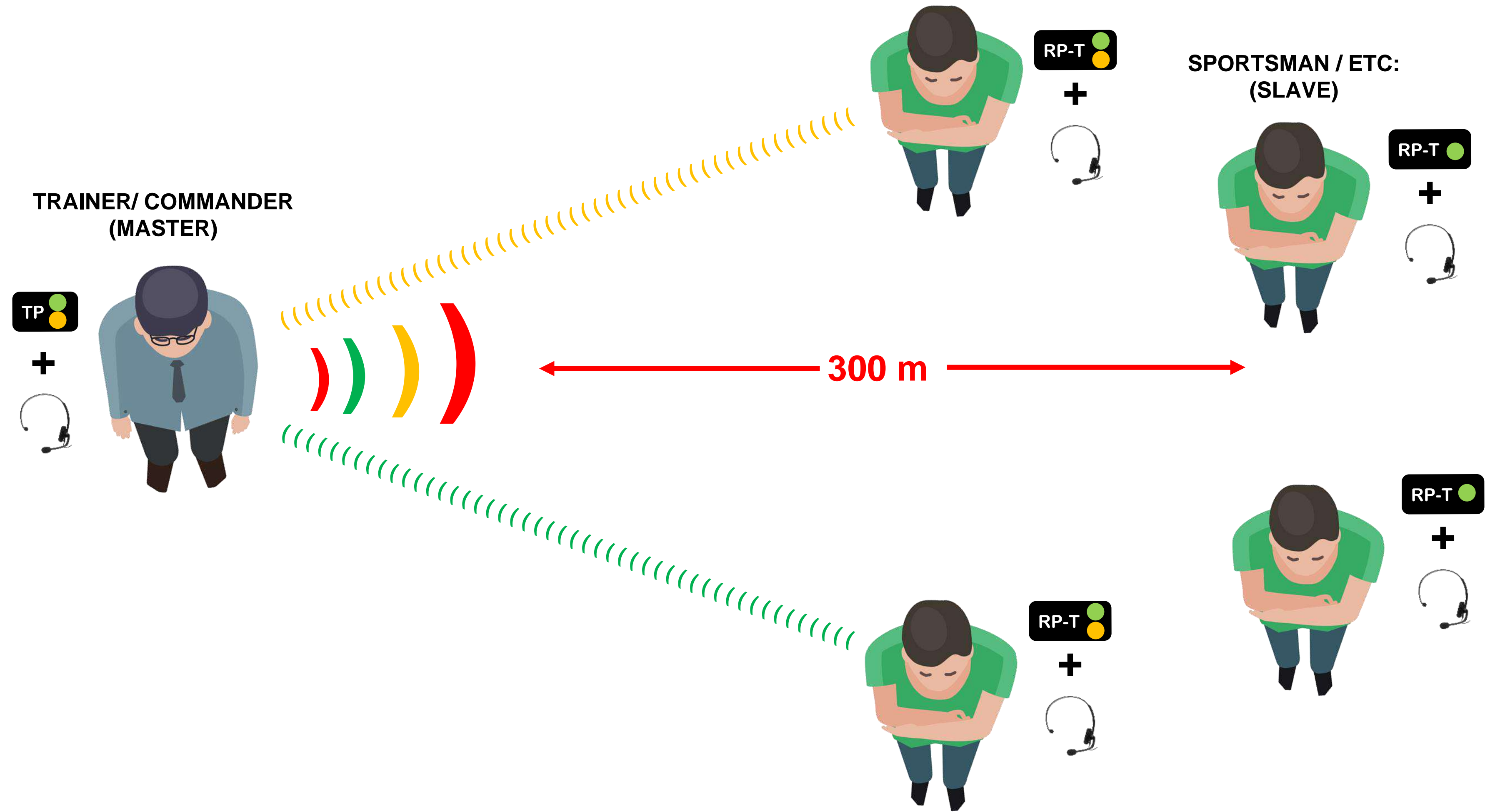









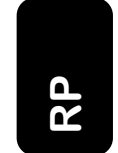
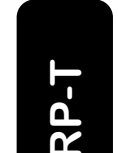

UNITE LEGEND









beyerdynamic))))

LEGEND



Unite Components

-  Unite TH
Handheld transmitter
-  Unite TP
Beltpack transmitter
-  Unite RP
Beltpack receiver
-  Unite RP-T
Beltpack receiver with talkback
-  Unite RP-H
Beltpack receiver high performance
-  Unite AP4
Access Point
-  Unite CC
Charging Case
-  Unite CF
19" Charger
-  Unite SG
19" Charging
Compartment
-  Unite CDS
Charging Device
-  Unite CDD
Charging Device











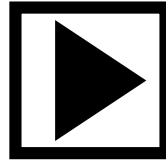

Accessoires

-  TG H56 (TG)
Neckworn microphone
-  HSP 121
Headset
-  DT 287 Unite
Headset
-  DT 1
Earphone
-  DT 2
Headphone
-  IL 200
Induction neckloop
-  DT 394.SIS
Headset
-  DT 770 PRO







Interpretation System

-  SIS
Control Unit Interpreter technology
-  SIS
Station Double interpreter station

3rd Party Components

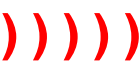
-  DSP DSP – digital signal processor
-  Switch
-  Mixer
-  Loudspeaker
-  Amplifier
-  Screen (Media Column)
-  Laptop
-  Ipod
-  Smartphone
-  TV
-  Smartboard
-  Table

Transmission

-  Transmit at the moment
-  Receive at the moment
-  Wireless point to point
transmission
-  Wireless broadcast
transmission
-  Cable Connection
-  Wireless Bluetooth Connection
- Master** Signals are routed via the master and
transmitted to the participants (with a
handheld or beltpack transmitter, you can
set it so that the signal can only be heard
at the master)
- Slave** Signals are transmitted from the slave to
the master, routed and then transmitted to
the participants
-  Languages

LEGEND



PRESENTER WITH HANDHELD OR BODYPACK TRANSMITTER



GUEST WITH RECEIVER TALKS WITH TALKBACK FUNCTION

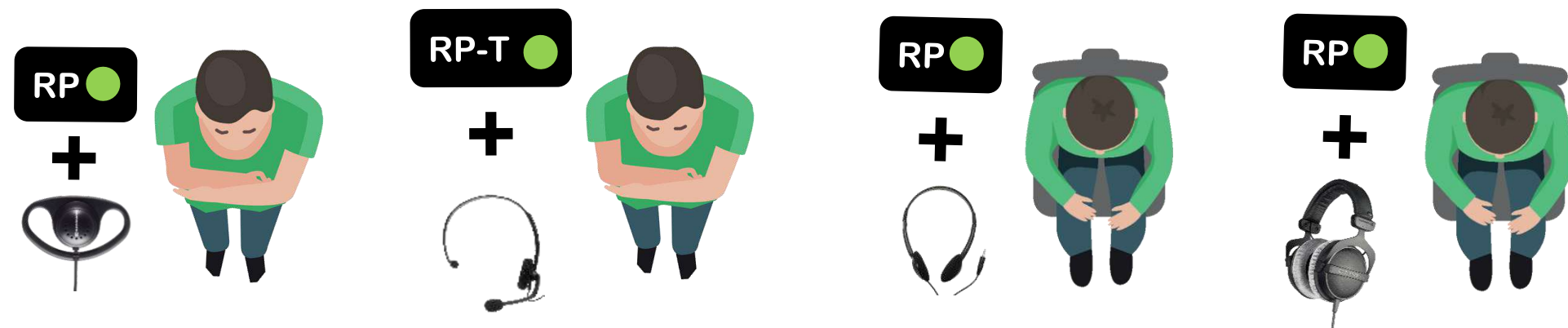

GUEST WITH RECEIVER AND HEADPHONE/HEADSET

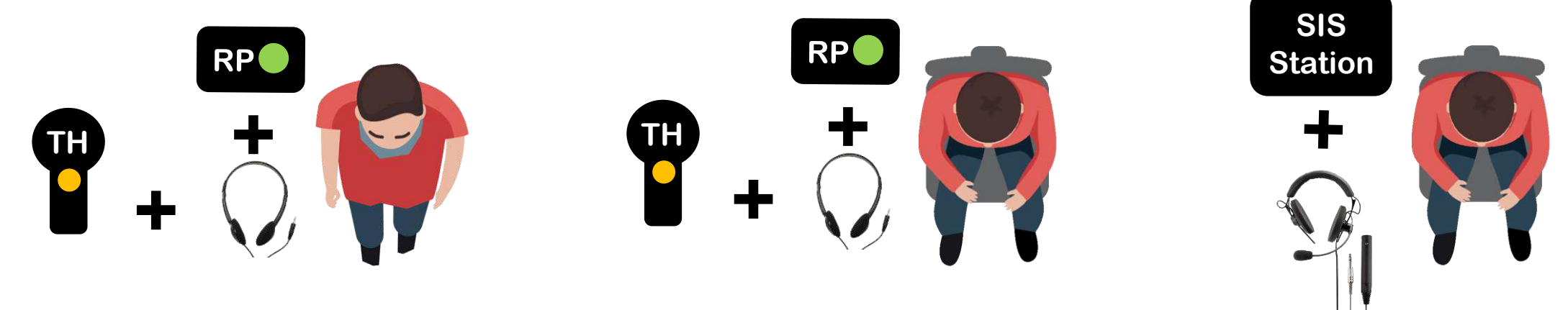

INTERPRETER WITH HANDHELD TRANSMITTER, BODYPACK RECEIVER AND HEADPHONE OR SIS INTERPRETER STATION



HARD OF HEARING WITH BODYPACK RECEIVER AND INDUCTION NECKLOOP



REPORTER WITH BODYPACK TRANSMITTER AND HEADSET